

IBM System p

IBM System p5 Virtualization in SAP Landscape



IBM Virtualization Solutions



SAP World Tour '06
Zagreb, 13.9.2006.
zorislav_sic@hr.ibm.com



IBM Systems

IBM's 39-year history of leadership in virtualization

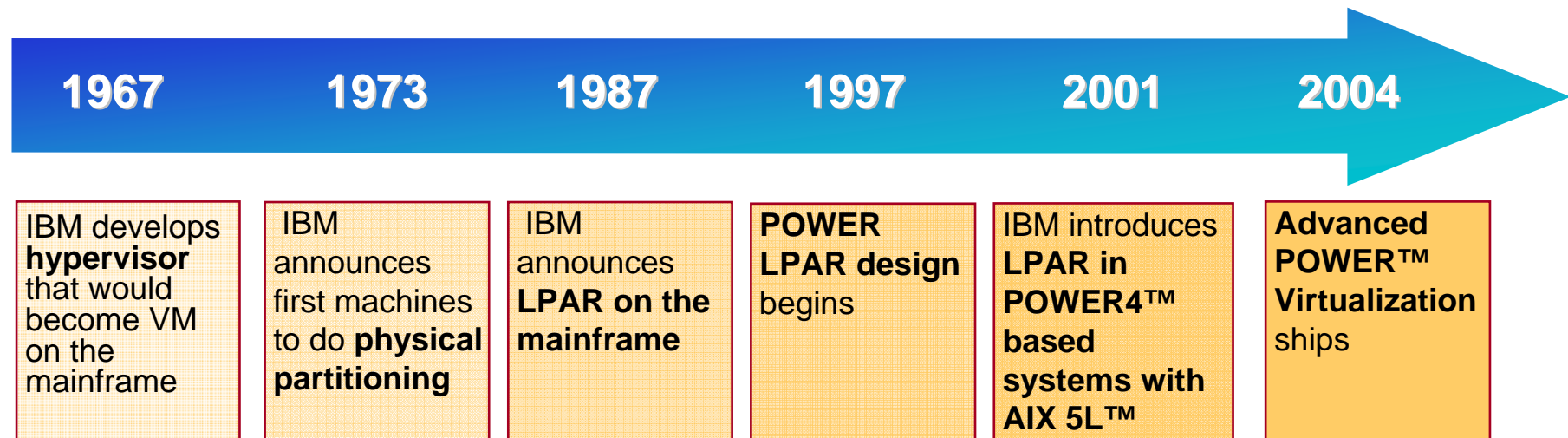

Timeline reference <http://www.levenez.com/unix/history.html#01>

Customer quote source: rku.it case study published at <http://www.ibm.com/software/success/cssdb.nsf/CS/JSTS-6KXPPG?OpenDocument&Site=eserverpseries>

Advanced POWER Virtualization option

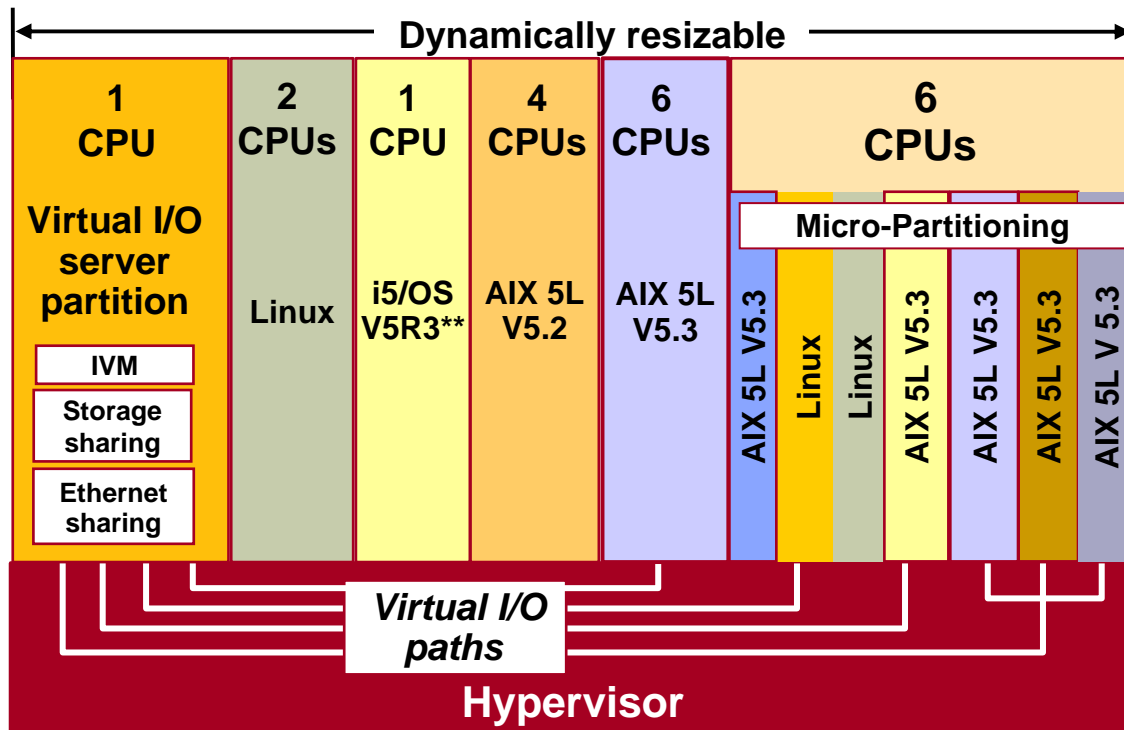

Virtual I/O Server

- Shared Ethernet
- Shared SCSI and Fibre Channel-attached disk subsystems
- Supports AIX 5L V5.3 and Linux* partitions

Micro-Partitioning

- Share processors across multiple partitions
- Minimum partition 1/10th processor
- AIX 5L V5.3, Linux*, or i5/OS**

Partition Load Manager

- Balances processor and memory request

Managed via HMC or IVM***

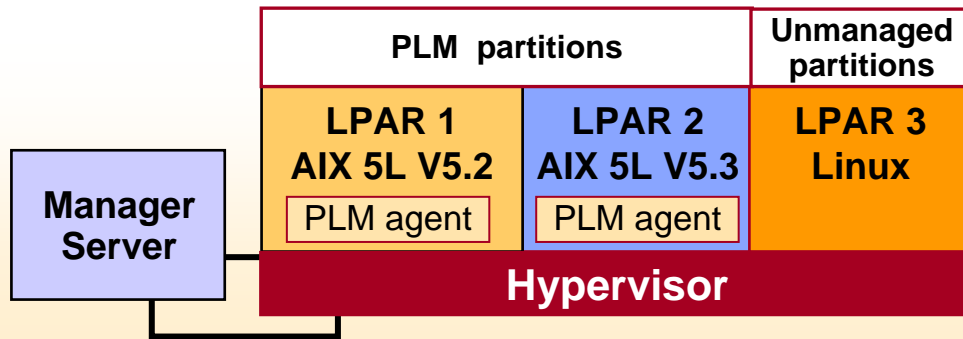

* SLES 9 or RHEL AS 4 and above

** Available on selected p5-570, p5-590 and p5-595 models

***IVM on p5-560Q and below

Shared Processor Partitions

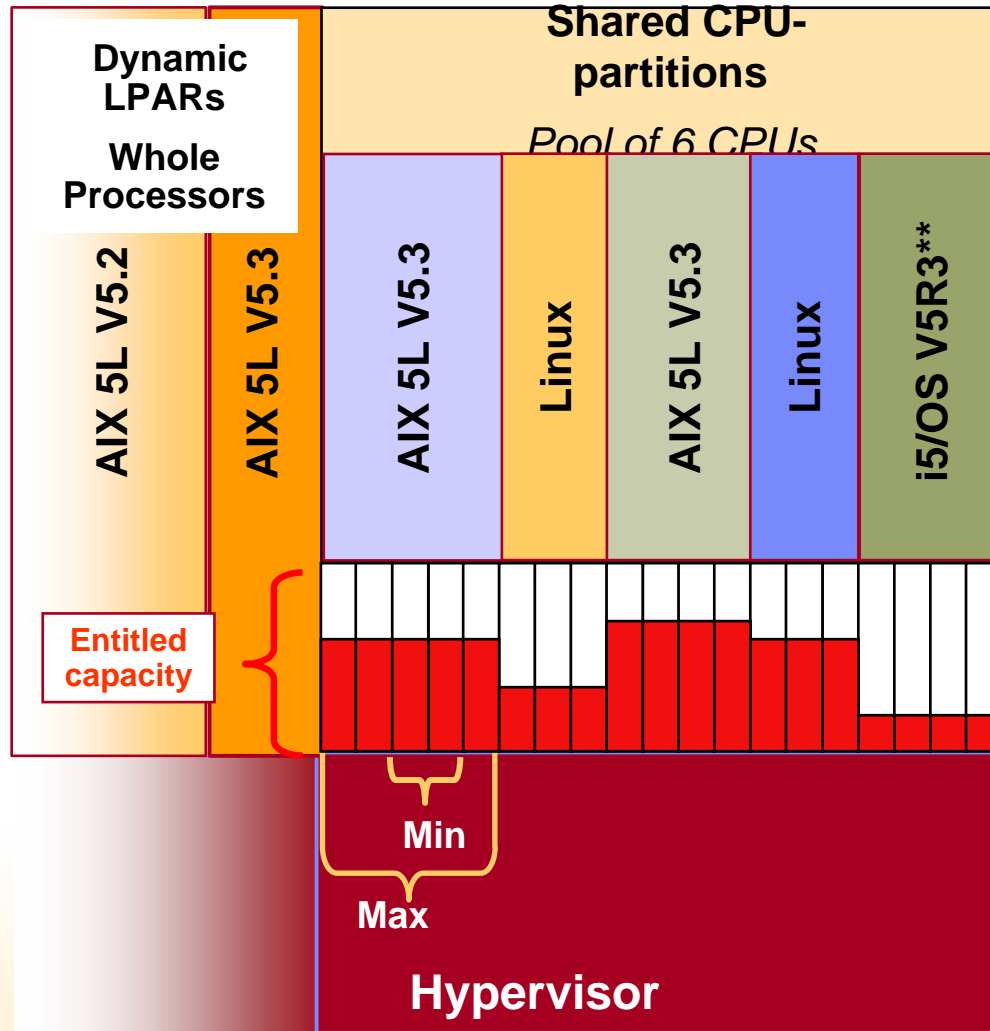

Note: Shared CPU partitions are available via optional Advanced POWER Virtualization or POWER Hypervisor and VIOS features.

Shared CPU technology allows each processor to be subdivided into as many as 10 “virtual servers”, helping to consolidate UNIX® and Linux applications.

Partitioning options

- Shared CPU-partitions: Up to 254*
- Dynamic LPARs: Up to 32*
- Combination of both

Configured via the HMC

Number of logical processors

- Minimum/maximum

Entitled capacity

- In units of 1/100 of a CPU
- Minimum 1/10 of a CPU

Variable weight

- % share (priority) of surplus capacity

Capped or uncapped partitions

*on p5-590 and p5-595
 ** on p5-570, p5-590, and p5-595

Virtual networking

Virtual Ethernet helps reduce hardware costs by sharing LAN adapters

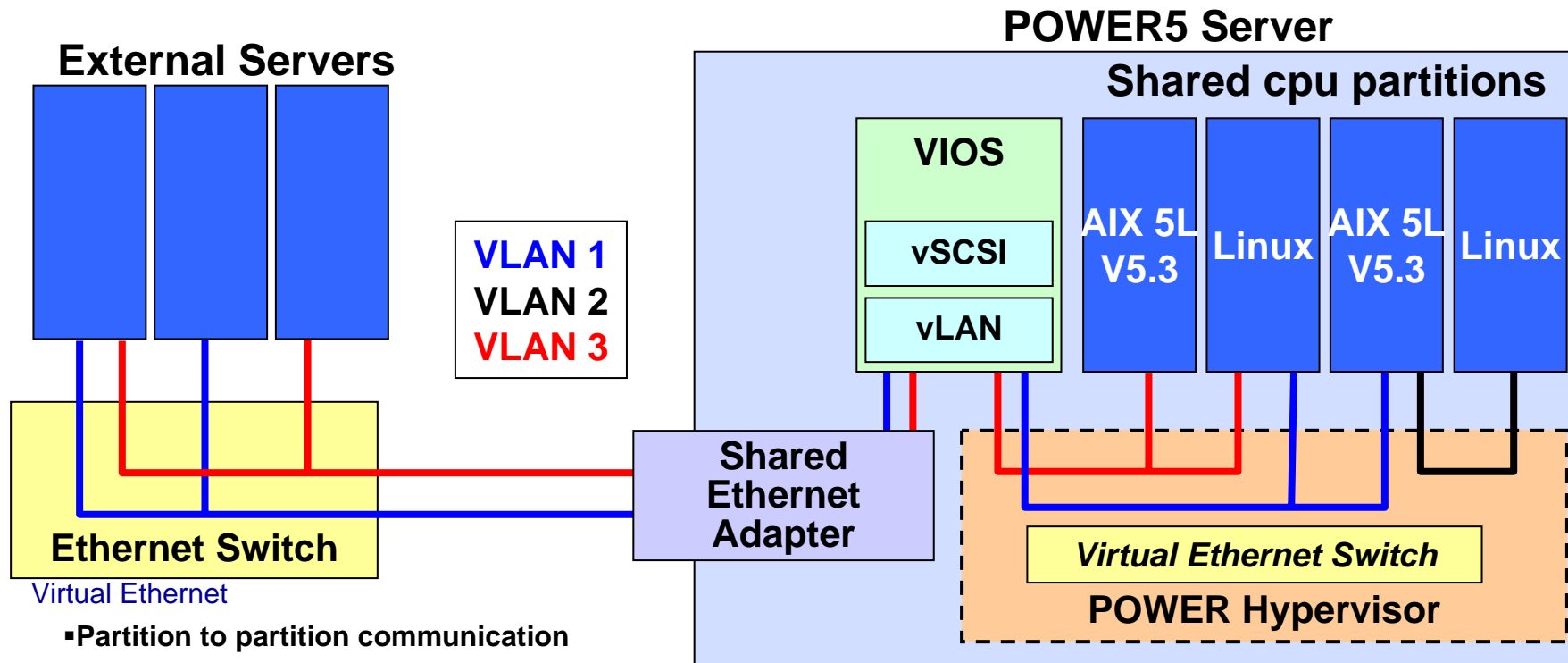

Virtual Ethernet

- Partition to partition communication
- Requires AIX 5L V5.3 and POWER5

Shared Ethernet Adapter

- Provides access to outside world
- Uses Physical Adapter in the Virtual I/O Server

VLAN – Virtual LAN

- Provide ability for one adapter to be on multiple subnets
- Provide isolation of communication to VLAN members
- Allows a single adapter to support multiple subnets

IEEE VLANS

- Up to 4096 VLANS
- Up to 65533 vENET adapters
- 21 VLANS per vENET adapter

Virtual SCSI

Virtual I/O helps reduce hardware costs by sharing disk drives

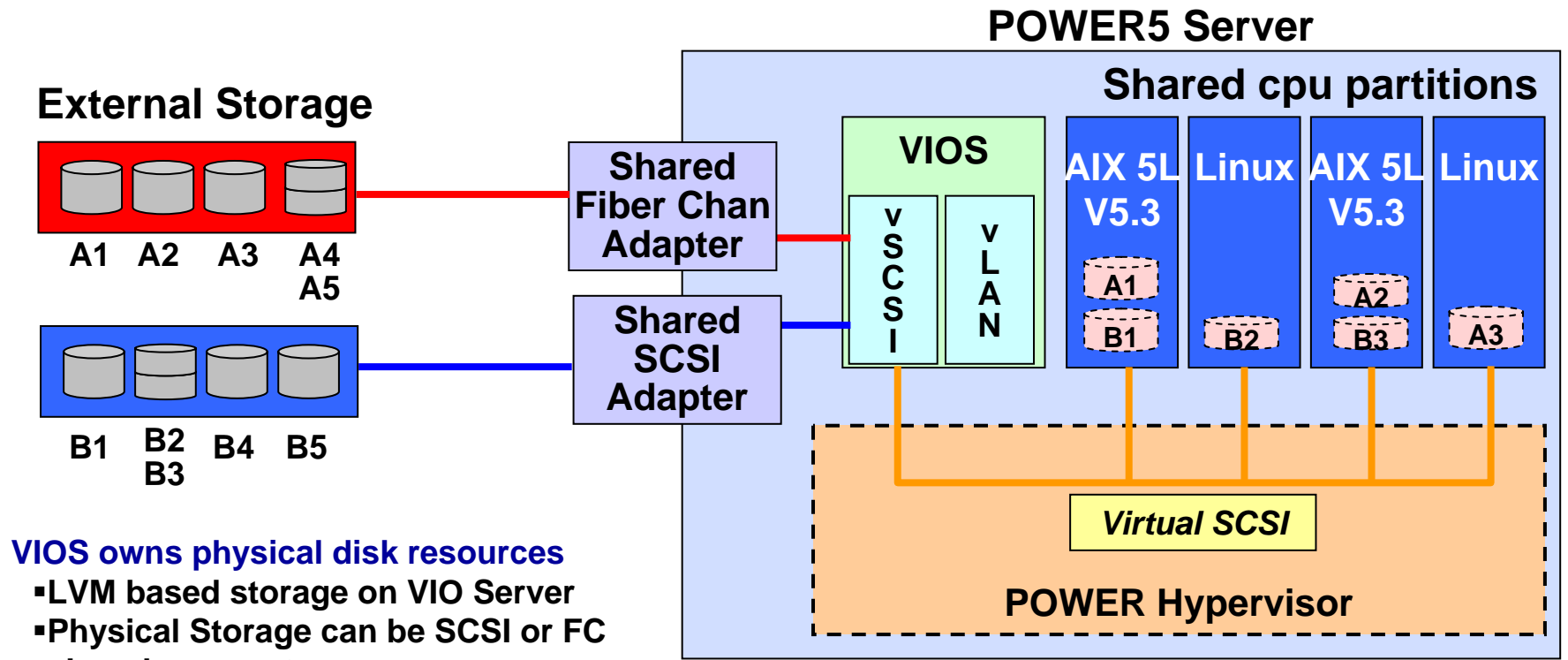

- VIOS owns physical disk resources**
- LVM based storage on VIO Server
 - Physical Storage can be SCSI or FC
 - Local or remote

- Micro-partition sees disks as vSCSI (Virtual SCSI) devices**
- Virtual SCSI devices added to partition via HMC or IVM
 - LUNs on VIOS accessed as vSCSI disk
 - VIOS must be active for client to boot

- Multiple LPARs can use same or different physical disk**
- Configure as logical volume on VIOS
 - Appear a hdisk on the micro-partition
 - Can assign entire hdisk to a single client

Available via optional Advanced POWER Virtualization or POWER Hypervisor and VIOS features.

System p5 and SAP Adaptive Computing

System p5 fully complies with Adaptive Computing initiative

Lower costs

- Increased CPU utilisation
- Smaller systems for SAP test environments
- Exactly tailorable system size for SAP middleware services

Improved business flexibility

- response to change in business needs

Improved manageability

Reduced infrastructure complexity

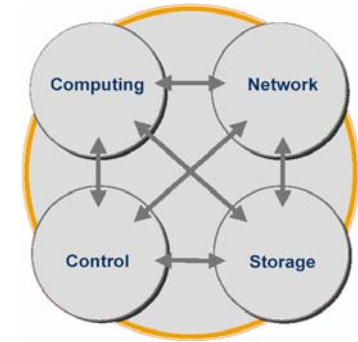

Combine functional Integration and Consolidation

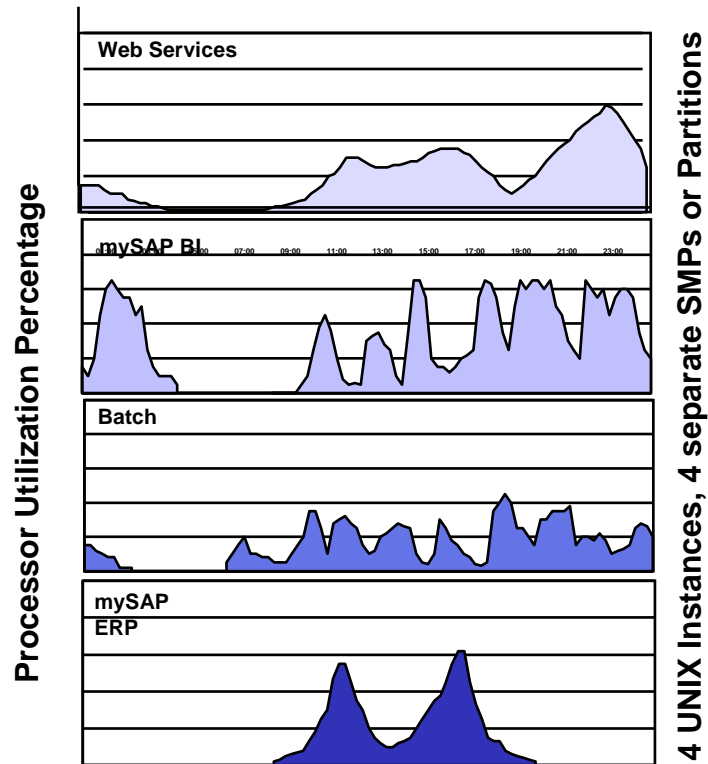

Many mySAP applications are integrated from a business and date perspective but not from a workloads point of view

They are managed as separate servers/LPARs

Results in low degree of synergy

- more hardware
- more software
- more work

While load changes significantly over time, capacity provided keeps constant.

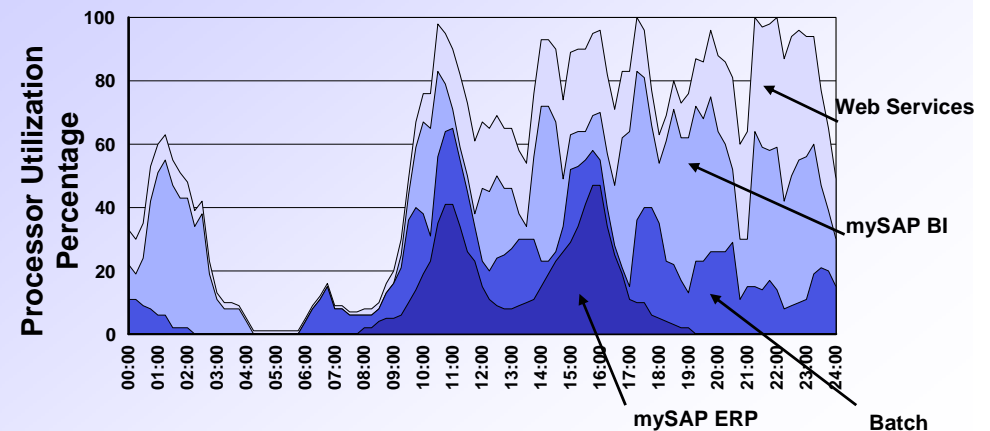

POWER5 processor-based systems and manageability features will allow for workload 'combination' while still keeping applications distinct

On Demand Computing for SAP delivered

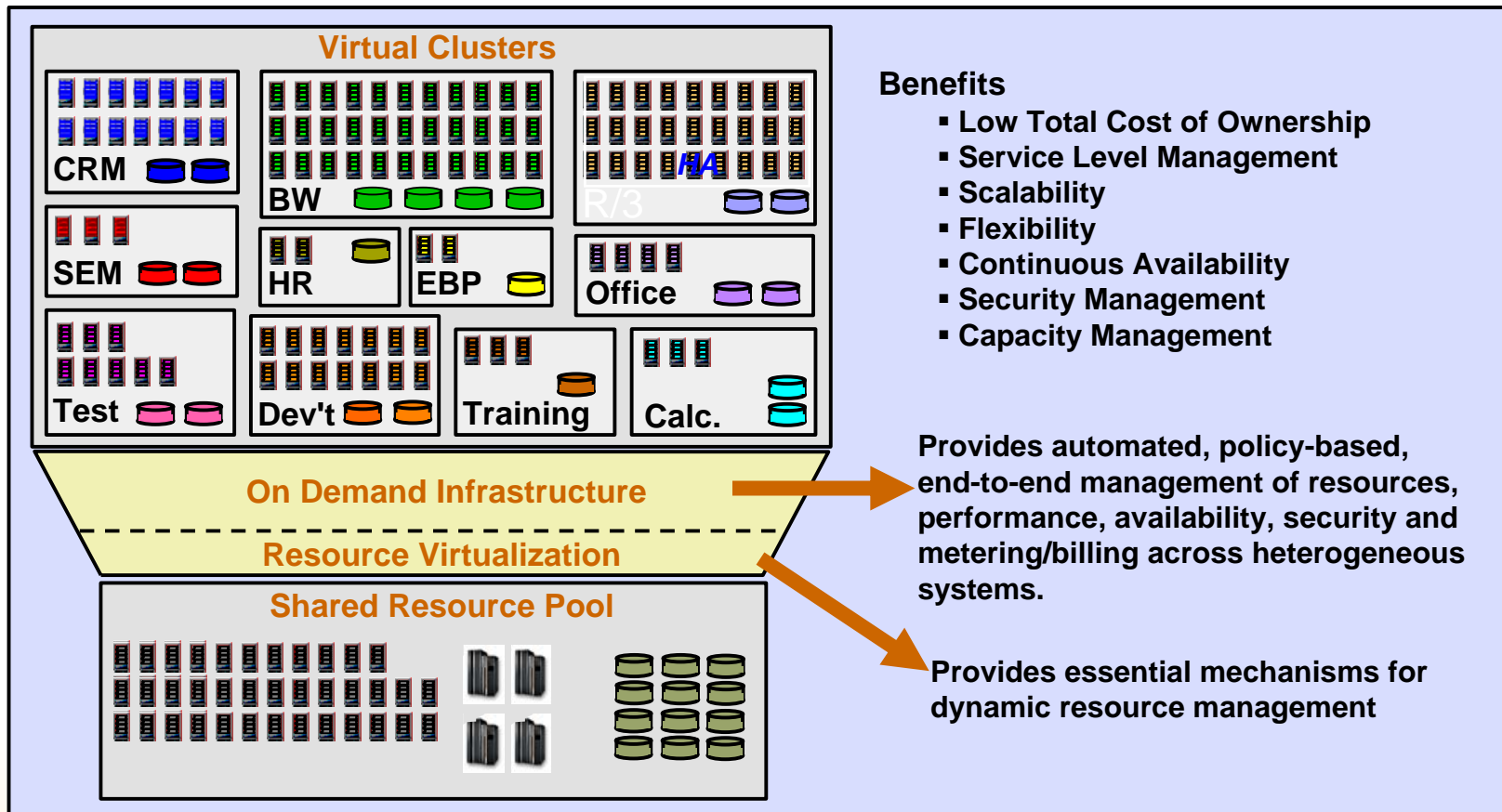

IT resources are pooled, virtualized, and allocated dynamically to satisfy changing business needs. Resources are well utilized, workload priorities are used to control consumption, and consumers pay for what they use.

Advanced POWER Virtualization and AIX 5L

IBM technology designed to help you do more while spending less!

- Industry-leading Virtualization features
- Leadership performance and availability
- Capabilities that support a reduced Total Cost of Ownership

*Advanced POWER Virtualization
on IBM System p servers*



AIX 5L

Contact IBM or your local IBM Business Partner

www.ibm.com/system/p